

## INSTALLATION INSTRUCTION

**KEEP ANTENNA AND CABLES AT A SAFE DISTANCE FROM ANY POWER LINES.  
TO PROTECT YOUR ANTENNA AND RECEIVER FROM LIGHTNING DAMAGE, ENSURE YOUR EQUIPMENT IS GROUNDED.**

### PACKAGE CONTENTS

- 1 x Antenna
- 4 x 10-32 Lock Nut
- 4 x #10 Flat Washer
- VSWR test result

### INSTALLATION OPTIONS

#### Panel Mounting

- Mount the antenna to the desired location using 4 protruding #10-32 screws, 4 flat washers, & 4 lock nuts
- Protruding screws #10-32 are equally spaced on a B.C.D. of 2.655" & can accommodate max. plate thickness of ¼"
- Attach the feed line to the antenna connector and weatherproof all connections appropriately

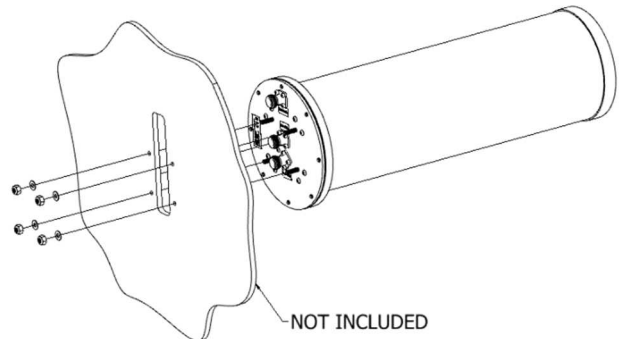
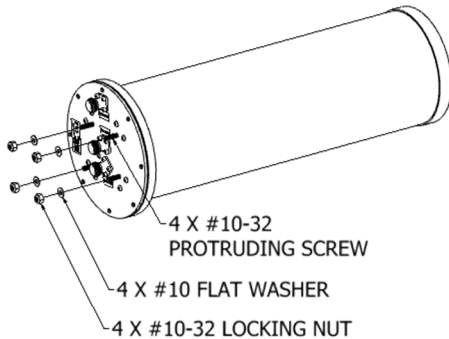

#### Bracket Mounting (Sold Separately, Part # 642224)

- Attach the mounting bracket to protruding #10-32 screws and secure it with #10 flat washers and 10-32 lock-nuts
- Attach the bracket to the mast using a mast clamp, U-bolt, 2 lock washers, & 2 nuts
- Mast clamp can accommodate mast size range from  $\varnothing 1 \frac{1}{4}$ " to 2.0"
- The bracket can be mounted directly to a flat surface held by at least 2 screws (screws not provided). The holes clearance is  $\varnothing 0.26$ "; use the appropriate screw size & length to secure the antenna in place
- Attach the feed line to the antenna connector and weatherproof all connections appropriately

