

D2212-S OMNIDIRECTIONAL VHF/VHF ANTENNA

WARNING!!

A QUALIFIED STRUCTURAL ENGINEER SHOULD BE CONSULTED PRIOR TO MOUNTING AN ANTENNA ON A TOWER OR SUPPORT STRUCTURE.

CLAMPING BLOCKS INSTALL

- 1) Insert clamping blocks at base of antenna aligned with holes in the side of clamp mount. The counter bored hole in the clamping blocks should align with the larger hole on its respective side of the clamp mount.
- 2) Slide the screw clamp through the supplied flat washer, the hole in the clamping mount and one of the clamping blocks then proceed to screw it into the second clamping block.
- 3) Repeat from other side using second clamping screw and flat washer.

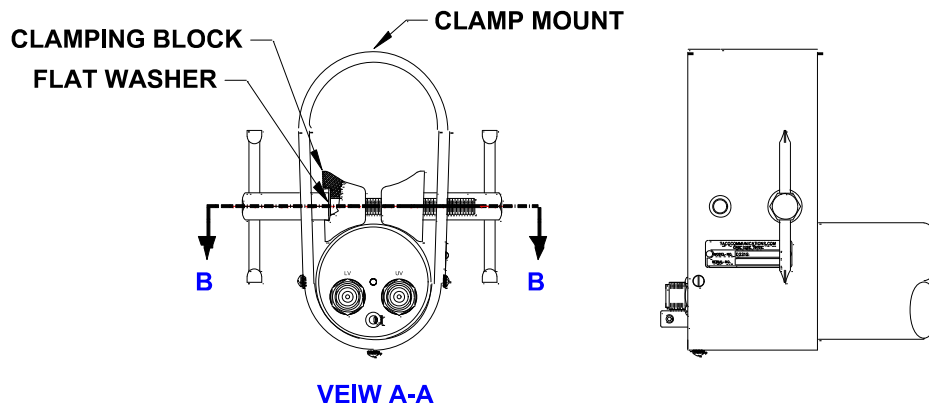
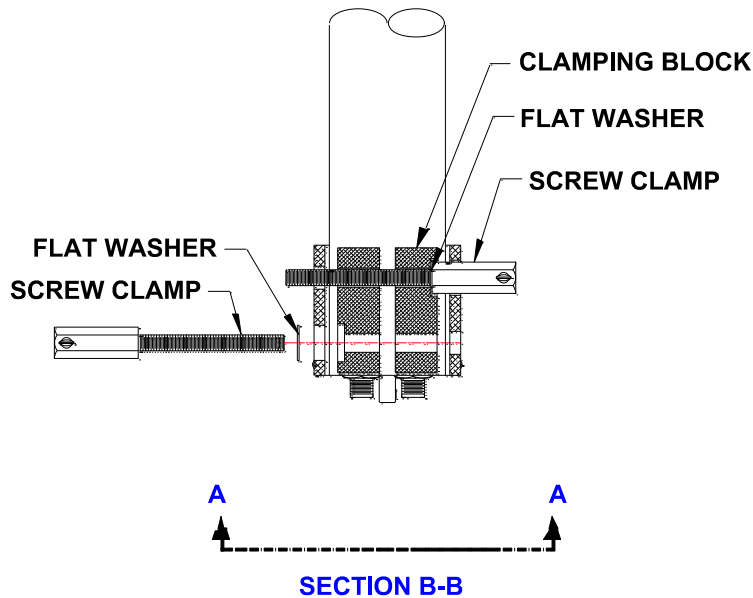

DISPOSAL INFORMATION

TACO Antenna is committed to meeting all requirements of the WEEE directive (2012/19/EU). The WEEE directive requires that manufacturers of electrical and electronic equipment who sell into EU countries: (1) label their equipment to notify customers that it needs to be recycled, and (2) ensure that their products are appropriately disposed of or recycled at the end of their lifespan. For collection and return of TACO products, please contact your European TACO Antenna representative or distribution partner.

